



UNRIVALLED QUALITY

P.O. Box 606, Creston, CA 93432

PHONE: 805.239.5972 FAX: 805.239.5973 EMAIL: info@jmrmanufacturing.com

ANTI-SPRING BACK KIT P/N ASB100

WARNING

**DO NOT USE THE ANTI-SPRING BACK KIT ON A
MECHANICAL OR HYDRAULIC BENDER.**

WARNING

1. Always pay close attention to what you are doing. Turn off cell phone, pager, etc when using this machine.
2. This machine is meant to be operated by competent individuals who have a thorough understanding of tube bending and machines in general.
3. The bender is intended to be used by a single operator. Never allow a second individual to operate the machine while another holds tube.
4. Always wear eye protection while operating tube bender.
5. Never put your hands or other body parts into bender apparatus.
6. Never wear loose clothing while operating tube bender.
7. Always work in a clean, safe, well lit, level work area.
8. Never use the wrong size die/type die for the tube being worked.
9. Never operate the tube bender with broken, worn or damaged parts.
10. DO NOT attempt to repair and reuse any damaged bender parts.
11. User assumes all risks when using this product.

NOTE

The JMR Manufacturing Anti-Spring Back Kit can be used on other brands of manual benders of similar style. But due to various design differences in those brands, it may be necessary to fabricate spacer sleeves.

INSTALL

CAUTION

DO NOT use any grease on the anti-spring back rod.

1. Figure 1 is an overall view of the Anti-spring back rod kit install.
2. Remove the nut, sleeve and bolt from the pivot arm. See Figure 2.

NOTE: The other bolt/nut on the pivot arm may have to be loosened to remove the sleeve.

3. Lightly grease and insert the sleeve into the release lever assembly Per Figure 2.

NOTE: The sleeve must be approx. .050 longer than the release lever assembly for proper operation. See Figure 3.

4. Install the release lever spring onto the release lever assembly as shown in Figure 2.
5. Locate the release lever assembly onto the pivot arm locating it over the bolt holes per Figure 2. Locate the release lever spring end over the pivot arm.
6. Install the bolt (from the bottom) through the pivot arm and securing it with the nut. Tighten securely but make sure the release lever assembly move freely. Retighten the other pivot arm bolt/nut if loosened in Step 2.
7. Remove the nut, washers, sleeve and bolt from the main arm. See Figure 3.
8. Install the collar and sleeve into the anti-spring back rod eye per Figure 3. DO NOT tighten collar set screw at this time.
9. Install the anti-spring back rod through the flag on the release lever assembly.
10. Install the rod eye into the main arm locating it over the bolt holes per Figure 3.
11. Install the bolt (from the top) and washer through the main arm and securing it with the washer and nut. Tighten very tight.
12. While pulling the release lever handle, carefully close the pivot arm against the main arm.

13. Locate the collar so the anti-spring back rod is parallel to the main and pivot arms per Figure 4 and tighten collar set screw.

CAUTION

The anti-spring back rod MUST be located parallel to the main and pivot arms for proper operation per Figure 4.

14. Cycle the pivot arm several times to insure the anti-spring back rod is not binding through the release lever assy. Some fine tuning of the collar position (up or down) may be required for smooth operation.

CAUTION

DO NOT use any grease on the anti-spring back rod.

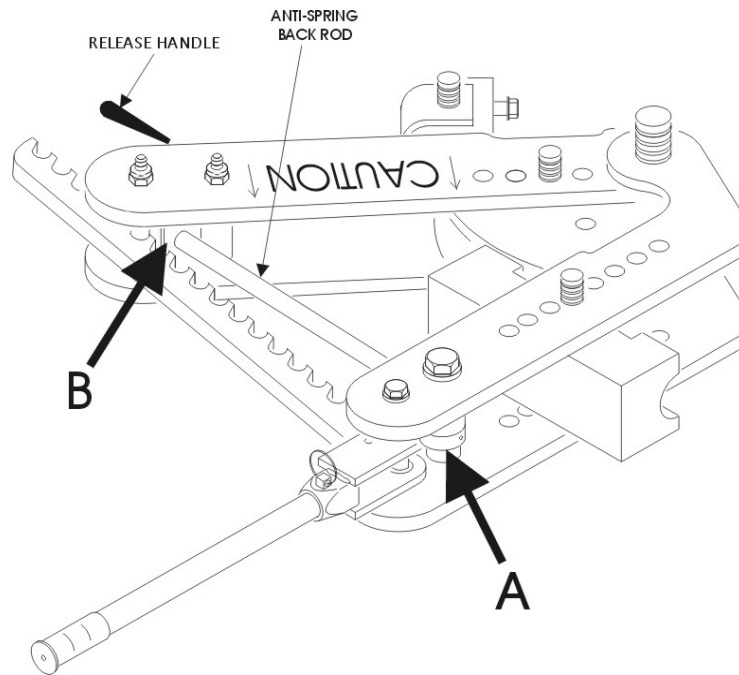

Figure 1. Overall

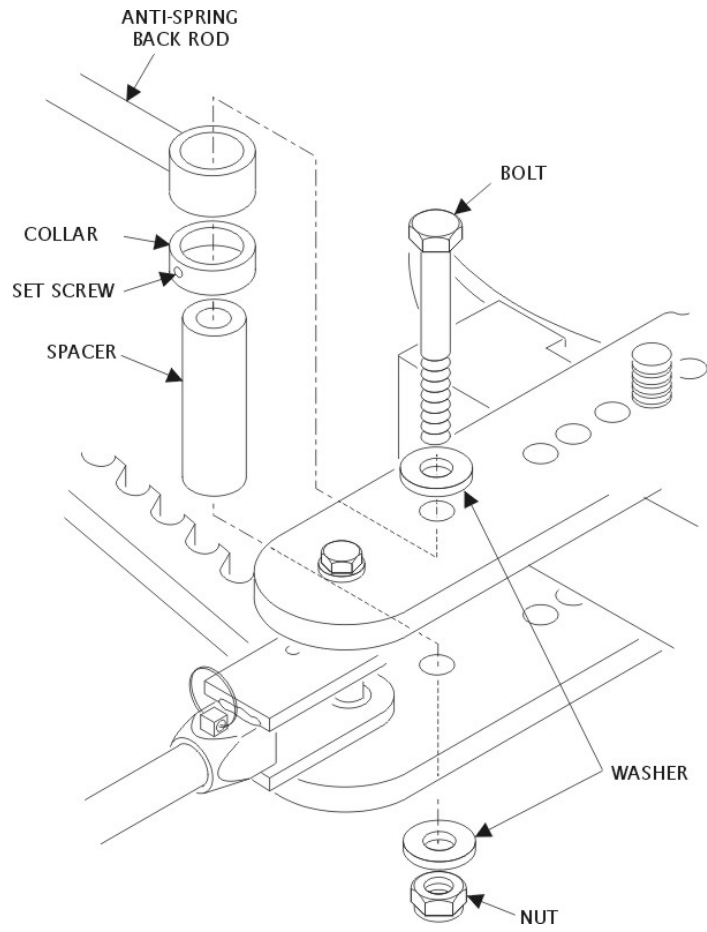

Figure 2.

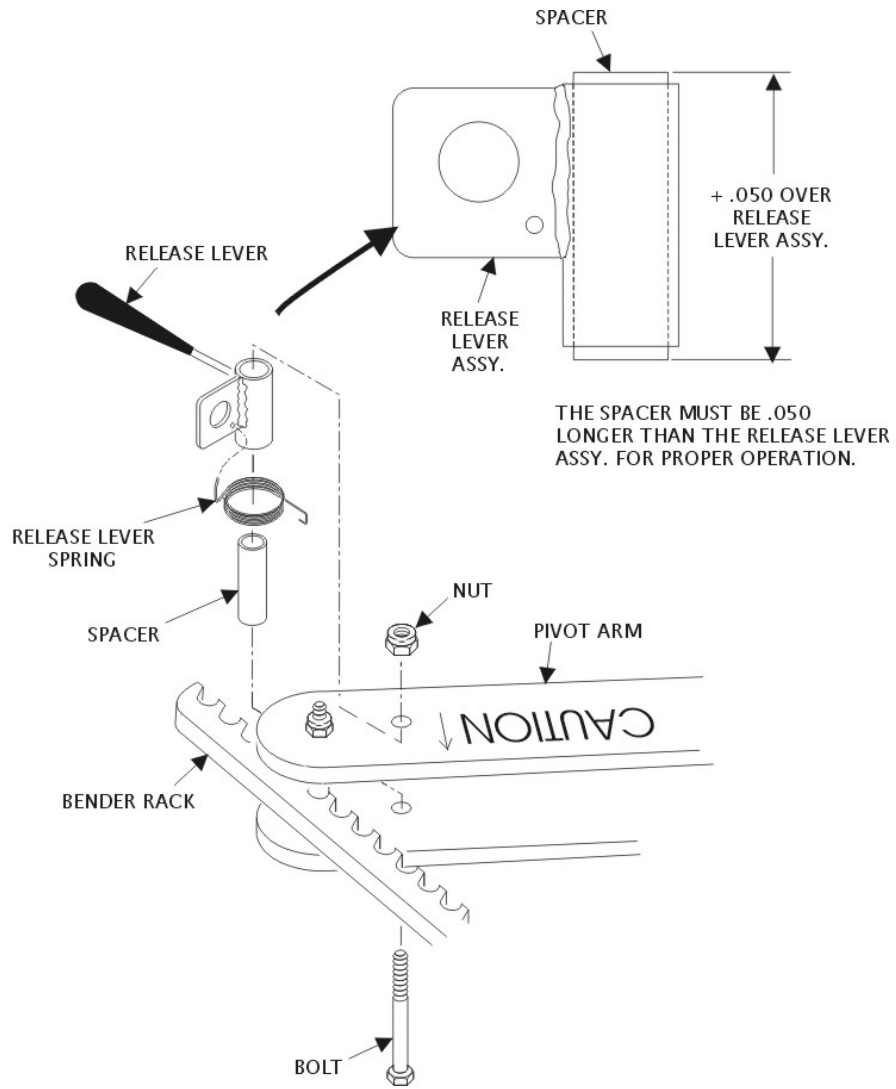

Figure 3.

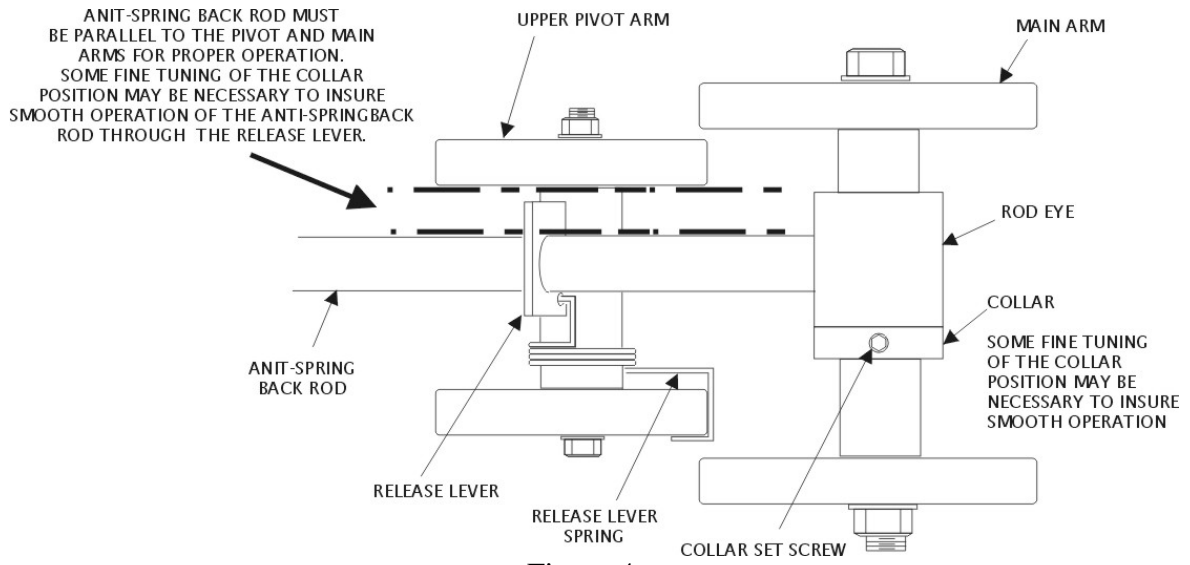

Figure 4.